

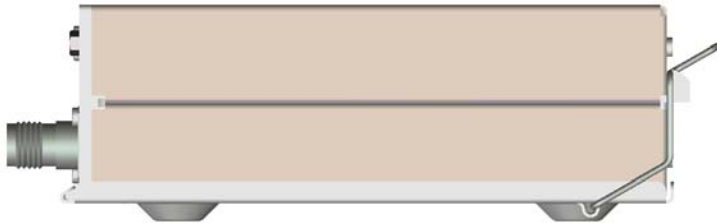

TT21/TT22 Mode S Transponder Installation Manual



00560-00-AK
15 March 2012

Trig Avionics Limited
Heriot Watt Research Park
Riccarton, Edinburgh
EH14 4AP
Scotland, UK

Copyright Trig Avionics Limited, 2012

This page intentionally left blank

CONTENTS

1. PREFACE.....	6
1.1 PURPOSE	6
1.2 SCOPE	6
1.3 CHANGES FROM PREVIOUS ISSUE.....	6
1.4 DOCUMENT CROSS-REFERENCES.....	7
2. INTRODUCTION	8
2.1 TT21/TT22 DESCRIPTION.....	8
2.2 INTERFACES	8
2.2.1 <i>TT21/TT22 Transponder Unit</i>	8
2.2.2 <i>TC20 Controller Unit</i>	9
3. TECHNICAL SPECIFICATIONS	10
3.1 TT21 TRANSPONDER UNIT (00675-00-01)	10
3.2 TT22 TRANSPONDER UNIT (00745-00-01)	11
3.3 TC20 CONTROL UNIT (00649-00)	12
3.4 INSTALLATION APPROVAL	13
4. UNIT AND ACCESSORIES SUPPLIED	14
4.1 TT21 MODE S TRANSPONDER ITEMS	14
4.2 TT22 MODE S TRANSPONDER ITEMS	14
4.3 TC20 CONTROLLER ITEMS.....	14
4.4 INSTALLATION KIT	14
4.5 REQUIRED ITEMS	15
5. INSTALLATION.....	17

5.1	UNPACKING AND INSPECTING EQUIPMENT	17
5.2	CONTROLLER MOUNTING	17
5.3	TRANSPONDER MAIN UNIT MOUNTING	18
5.4	COOLING REQUIREMENTS	18
5.5	TT21/TT22 TRANSPONDER ELECTRICAL CONNECTIONS	19
5.5.1	<i>TT21/TT22 Interface – Pinout</i>	19
5.6	TT21/TT22 TRANSPONDER INTERFACE DETAILS	20
5.6.1	<i>Power Input</i>	20
5.6.2	<i>TMAP Bus</i>	21
5.6.3	<i>Power On</i>	21
5.6.4	<i>Controller Power</i>	21
5.6.5	<i>Mutual Suppression</i>	21
5.6.6	<i>Ident Switch Input</i>	22
5.6.7	<i>Squat Switch Input</i>	22
5.6.8	<i>External Standby Input</i>	22
5.6.9	<i>GPS Position Input</i>	22
5.6.10	<i>TIS Traffic Output</i>	23
5.7	TC20 CONTROLLER ELECTRICAL CONNECTIONS.....	23
5.7.1	<i>TC20 Interface - Pinout</i>	23
5.8	TC20 CONTROLLER INTERFACE DETAILS	24
5.8.1	<i>TMAP Bus</i>	24
5.8.2	<i>Altitude Out</i>	24
5.8.3	<i>Remote ON</i>	25
5.8.4	<i>Power</i>	25

5.9	D CONNECTOR CRIMP TERMINALS	25
5.10	WIRING CONSIDERATIONS	26
5.11	ANTENNA INSTALLATION	27
5.11.1	<i>Antenna Ground Plane</i>	28
5.11.2	<i>Antenna Cable</i>	28
5.11.3	<i>TNC Connector</i>	31
5.12	STATIC PRESSURE CONNECTION	32
6.	INSTALLATION SETUP AND TEST	34
6.1	CONFIGURATION ITEMS	34
6.1.1	<i>Aircraft Address Programming</i>	34
6.1.2	<i>VFR Squawk Code</i>	35
6.1.3	<i>VFR Flight ID</i>	35
6.1.4	<i>Airspeed Category</i>	35
6.1.5	<i>Aircraft Category</i>	36
6.1.6	<i>Squat Switch Source</i>	36
6.1.7	<i>TIS Output</i>	36
6.1.8	<i>GPS Input</i>	36
6.1.9	<i>GPS/TIS Line Speed</i>	36
6.1.10	<i>GPS Certification Level</i>	37
6.1.11	<i>GPS NAC velocity</i>	37
6.1.12	<i>Aircraft Length and Width</i>	37
6.1.13	<i>GPS Antenna Offset</i>	37
6.1.14	<i>1090 MHz Receiver Installed</i>	38
6.1.15	<i>UAT Receiver Installed</i>	38

6.2	TEST AND CALIBRATION ITEMS.....	38
6.2.1	<i>Voltage Check</i>	38
6.2.2	<i>Altitude Encoder Calibration</i>	39
7.	POST INSTALLATION CHECKS.....	43
8.	NORMAL OPERATION.....	44
8.1	OVERVIEW.....	44
8.2	DISPLAY.....	44
8.3	MODE SELECTOR KNOB.....	45
8.4	PUSH BUTTONS.....	45
8.5	CODE SELECTOR KNOB.....	45
8.6	ALTITUDE ENCODER WARM UP.....	46
8.7	GENERAL LOW TEMPERATURE OPERATION.....	46
8.8	ADS-B MONITOR.....	47
8.9	WARNING MESSAGES.....	47
8.10	FAULT ANNUNCIATION.....	47
9.	CONTINUED AIRWORTHINESS.....	48
10.	LIMITED WARRANTY.....	49
11.	ENVIRONMENTAL QUALIFICATION FORMS.....	50
12.	ADS-B COMPLIANCE.....	56
12.1	ADS-B PARAMETERS SUPPORTED.....	56
12.2	FAA 91.227 COMPLIANCE.....	57
12.3	AMC 20-24 COMPLIANCE.....	57

12.4	AUTOMATIC AIR/GROUND DETERMINATION	58
12.5	ADS-B SUPPORT	58
13.	INSTALLATION DRAWINGS	59
13.1	MOUNTING TRAY FIXING AND OVERALL DIMENSIONS	59
13.2	FRONT PANEL CONTROLLER DIMENSIONS	60
13.3	FRONT PANEL CUT-OUT OPTIONS	61
14.	BASIC INTERCONNECT DIAGRAM.....	63

1. Preface

1.1 Purpose

This manual describes the physical and electrical characteristics and the installation requirements for a TT21/TT22 Mode S Transponder and associated TC20 controller.

1.2 Scope

This document applies to the installation of the TT21 or TT22 Mode S Transponder.

At the publication date of this manual the software version identifier for the TT21 and TT22 is 2.1 and the FPGA version identifier is 1.2. The TC20 controller software version identifier is 1.6. The software and FPGA versions are subject to change without notice.

1.3 Changes from Previous Issue

Changes from Issue AJ to Issue AK are:

- | | |
|----------------|--|
| Section 4 | Minor editorial changes |
| Section 5.6.9 | New Garmin ADS-B compatibility added. |
| Section 5.6.10 | Corrected error listing secondary connector |
| Section 8.3 | Behaviour of automatic air/ground switching added. |
| Section 8.4 | ADS-B monitor functionality added. |
| Section 12 | Major rewrite to reflect DO-260B functionality and compliance, including:
NACv parameter added. |

Additional compatible GPS devices added.

ADS-B air/ground determination explained.

1.4 Document Cross-References

00559-00	TT21 Mode S Transponder Operating Manual	AE
----------	--	----

2. Introduction

2.1 TT21/TT22 Description

The TT21/TT22 Mode S transponder system is an ED-73C compliant Mode S level 2els datalink transponder, with support for ADS-B extended squitter, elementary surveillance and SI codes, which also meets the relevant environmental requirements of ED-14F. The TT21 has a nominal power output of 125 Watts, and meets the power output requirements for Class 2. The TT22 has a nominal power output of 250 watts, and meets the power output requirements for Class 1. The ADS-B function meets DO-260B class B0 for the TT21 and class B1S for the TT22. The TT21/TT22 is certified to ETSO 2C112b and ETSO C166a, and to FAA TSO C112c and C166b.

The TT21/TT22 transponder is controlled using a separate front panel controller, called the TC20. This allows the transponder to be mounted separately from the instrument panel, and reduces the amount of panel space taken by the transponder. The TC20 includes an altitude encoder. The TC20 is certified to ETSO 2C112b and ETSO C88a, and to FAA TSO C112c and TSO C88b.

The TT21/TT22 transponder runs from either 14 volt nominal or 28 volt nominal DC power supply with no configuration changes required.

The TT21/TT22 transponder responds to both legacy Mode A/C interrogations and to Mode S interrogations from both ground radar and airborne collision avoidance systems. In all cases, the interrogations are received by the transponder on 1030MHz, and replies are transmitted on 1090MHz.

2.2 Interfaces

2.2.1 TT21/TT22 Transponder Unit

The main transponder unit has a single TNC antenna connection and a single 25 way D-type connector. The 25 way D-type interface provides the following services:

Power Input	The TT21/TT22 operates on 11 to 33 Volts DC.
Front Panel Datalink	A two wire data link is used to connect the TT21/TT22 and the controller.
Front Panel Power	The controller is powered from the transponder.
Remote On/Off	The on-off switching is on the controller, and switches this input.
Ident input	External IDENT switch input.
Standby input	External standby input for dual transponder installations.
“On ground” input	Allows automatic flight/ground mode switching for aircraft with a squat switch.
Suppression bus I/O	ARINC compatible suppression bus signal used in aircraft with other pulse equipment, such as DME. This pin is both an input to and output from the transponder.
GPS Input	Connection to a GPS supplying position input for ADS-B position reporting.
TIS Output	Connection to a traffic display.

2.2.2 TC20 Controller Unit

The TC20 controller has a single 9 way D-type connector. It provides the following services:

Power Input	The controller receives power from the transponder.
Front Panel Datalink	A two wire data link is used to connect the TT21/TT22 and the controller.
Remote On/Off	The on-off switching is on the controller, and controls this output.
Altitude Output	An additional serial output on the TC20 provides pressure altitude information that can be used for baro-aiding by certain GPS receivers.

3. Technical Specifications

3.1 TT21 Transponder Unit (00675-00-01)

Specification	Characteristics
Compliance	ETSO 2C112b Class 2 Level 2els, ETSO C166a Class B0, TSO C112c Class 2 Level 2els, TSO C166b Class B0
FCC Identification	VZI00675
Applicable documents	EUROCAE ED-73C, EUROCAE ED-14F (RTCA DO-160F), RTCA DO-181D, RTCA DO-260B
Software	ED-12B (RTCA DO-178B) Level B
Hardware	DO-254 Level C
Power Requirements	11 – 33 Volts DC. Typical 5 Watts @ 14Volts.
Altitude	35,000 feet
Humidity	95% @ +50°C for 6 hours; 85% @ +38°C for 16 hours. Tested to Category A in DO-160F
Operating Temperature	-20°C to +70°C
Transmitter Frequency	1090MHz ± 1MHz
Transmitter Power	125 Watts nominal; 71 Watts minimum at antenna after allowing for 0.5dB connector losses and 1.5dB cable losses.
Transmitter Modulation	6M75 V1D
Receiver Frequency	1030 MHz
Receiver Sensitivity	-74dBm ± 3dB

Physical Specifications (in the mounting tray)

Height	48mm (1.9")
Width	66mm (2.5")
Length	160mm (6.3")
Weight	0.77lbs. (350 g)

3.2 TT22 Transponder Unit (00745-00-01)

Specification	Characteristics
Compliance	ETSO 2C112b Class 1 Level 2els, ETSO C166a Class B0, TSO C112c Class 1 Level 2els, TSO C166b Class B1S
FCC Identification	VZI00745
Applicable documents	EUROCAE ED-73C, EUROCAE ED-14F (RTCA DO-160F), RTCA DO-181D, RTCA DO-260B
Software	ED-12B (RTCA DO-178B) Level B
Hardware	DO-254 Level C
Power Requirements	11 – 33 Volts DC. Typical 6 Watts @ 14Volts.
Altitude	35,000 feet
Humidity	Tested to Category A in DO-160F
Operating Temperature	-20°C to +70°C
Transmitter Frequency	1090MHz ± 1MHz
Transmitter Power	250 Watts nominal; 125 Watts minimum at antenna after allowing for 0.5dB connector losses and 1.5dB cable losses.
Transmitter Modulation	6M75 V1D

Receiver Frequency	1030 MHz
Receiver Sensitivity	-74dBm \pm 3dB
Physical Specifications (in the mounting tray)	
Height	48mm (1.9")
Width	66mm (2.5")
Length	160mm (6.3")
Weight	0.77lbs. (350 g)

3.3 TC20 Control Unit (00649-00)

Specification	Characteristics
Compliance	ETSO 2C112b, ETSO C88a, TSO C112c, TSO C88b
Applicable documents	EUROCAE ED-73B, EUROCAE ED-14F (RTCA DO-160F), RTCA DO-181D, SAE 8003
Software	ED-12B (RTCA DO-178B) Level B
Altitude	-1000 to 35,000 feet
Humidity	95% @ +50°C for 6 hours; 85% @ +38°C for 16 hours. Tested to Category A in DO-160F
Operating Temperature	-20°C to +55°C
Physical Specifications (behind the panel)	
Height	44mm (1.8")
Width	63mm (2.4")
Length	54mm (2.1")
Weight	0.11lbs. (90 g)

3.4 Installation Approval

The conditions and tests required for the TSO approval of the TT21/TT22 Mode S Transponder are minimum performance standards. It is the responsibility of those desiring to install this transponder on or within a specific type or class of aircraft to determine that the aircraft operating conditions are within the TSO standards. The transponder may be installed only if further evaluation by the user/installer documents an acceptable installation that is approved by the appropriate airworthiness authority.

4. Unit and Accessories supplied

4.1 TT21 Mode S Transponder Items

The TT21 Mode S transponder includes the following items:

Unit Description	Qty	Part Number
TT21 Mode S Transponder	1	00675-00-01
TT21/TT22 Mounting Tray	1	00667-00

4.2 TT22 Mode S Transponder Items

The TT22 Mode S transponder includes the following items:

Unit Description	Qty	Part Number
TT22 Mode S Transponder	1	00745-00-01
TT21/TT22 Mounting Tray	1	00667-00

4.3 TC20 Controller Items

The TC20 controller includes the following items:

Unit Description	Qty	Part Number
TC20 Transponder Controller	1	00649-00
TT21/TT22 Installation Kit	1	00668-00

4.4 Installation Kit

The TT21/TT22 installation kit includes the following items:

Unit Description	Qty	Part Number
TT21/TT22 Transponder Installation	1	00560-00

Manual		
TT21/TT22 Pilots Operating Manual	1	00559-00
Mounting adapter (circular hole adapter)	2	00678-00
Connector Co-axial TNC	1	00723-00
Headshell, 9 Way	1	00725-00
Headshell, 25 way	1	00726-00
9 way D-type contact housing (female)	1	00727-00
25 way D-type contact housing (male)	1	00728-00
Crimp Terminal, Male, 22-24 AWG	20	00729-00
Crimp Terminal, Female, 22-24 AWG	9	00730-00
Static tubing, EPDM 5mm ID	1	00731-00
Hose T piece	1	00732-00
Hose Adapter	2	00733-00
Hose clip, small	6	00734-00
Hose clip, large	2	00735-00
Long mounting screws, 4-40 thread	4	00736-00
Short mounting screws, 4-40 thread	4	00737-00

4.5 Required Items

Additional items you will require, but which are not in the TT21/TT22 package, include:

- Antenna and fixing hardware. The TT21/TT22 is compatible with any transponder antenna approved to ETSO C74 or 2C112.
- Cables. You need to supply and fabricate all required cables. Guidance on cable types is given in section 5 below.
- Fixings. To secure the transponder tray to the airframe you will need

at least 3 flat head screws and three self-locking nuts. If the aircraft does not have existing mounting provisions you may need to fabricate additional brackets to support the transponder tray.

To support the optional ADS-B features a GPS receiver with an appropriate serial output is required. To support the optional TIS features a display with an appropriate serial input is required.

5. Installation

5.1 Unpacking and Inspecting Equipment

Carefully unpack the transponder and make a visual inspection of the unit for evidence of any damage incurred during shipment. If the unit is damaged, notify the shipping company to file a claim for the damage. To justify your claim, save the original shipping container and all packaging materials.

5.2 Controller Mounting

The TC20 transponder controller must be mounted rigidly in the aircraft panel. The controller can be mounted in the ultra compact mounting hole or in a conventional 57mm (2¼ inch) instrument cut-out.

The following installation procedure should be followed, remembering to allow adequate space for installation of cables and connectors.

- Select a position in the panel that is not too close to any high external heat source. (The TC20 is not a significant heat source itself and does not need to be kept away from other devices for this reason).
- Avoid sharp bends and placing the cables too near to the aircraft control cables.

If you are using a 57mm instrument cut-out, you must first clip the two mounting adapters to the transponder. The controller should then be mounted using the four LONG screws provided.

Note: The mounting adapters are held in place by the clamping action of the panel installation. As an aid to securing them during assembly when access is poor, we recommend putting a rubber band around the adapters and the control head. The rubber band can be snipped off and discarded when the installation is complete.

If you are using the Trig compact cut-out, you do not need the mounting adapters. The controller should be mounted using the four SHORT screws provided. The screws supplied are appropriate for panel thicknesses from 3

mm to 5 mm. If a thinner panel is used, you may need to exchange the screws for shorter versions since they can bottom out in the mounting holes.

If alternate screws are required, please note that the mounting thread in each case is 4-40.

5.3 Transponder Main Unit Mounting

The TT21/TT22 Mode S transponder is designed to be mounted in any convenient location in the cockpit, the cabin, or an avionics bay.

The following installation procedure should be followed, remembering to allow adequate space for installation of cables and connectors.

- Select a position in the aircraft that is not too close to any high external heat source. (The TT21/TT22 is not a significant heat source itself and does not need to be kept away from other devices for this reason).
- Avoid sharp bends and placing the cables too near to the aircraft control cables.
- Secure the mounting tray (p/n 00667-00) to the aircraft via the three (3) mounting holes in the tray. The tray should be mounted to a flat surface - it is important that the tray is supported at the dimples as well as the three mounting points.
- Put the TT21/TT22 transponder into the secured mounting tray by hooking the connector end under the lip on the tray.
- Lock the TT21/TT22 transponder into the mounting tray by clipping the retaining wire over the lugs on the opposite end.

5.4 Cooling Requirements

The TT21/TT22 Mode S transponder meets all applicable ETSO requirements without forced air-cooling.

Attention should however be given to the incorporation of cooling provisions to limit the maximum operating temperature if the TT21/TT22 is installed in

close proximity to other avionics. The reliability of equipment operating in close proximity in an avionics bay can be degraded if adequate cooling is not provided.

5.5 TT21/TT22 Transponder Electrical Connections

The TT21/TT22 has a single 25 way female socket which provides the data and power inputs to the transponder. A single TNC coaxial connector attaches to the antenna.

5.5.1 TT21/TT22 Interface – Pinout

Pin	Signal	Direction
1	Ground	-
2	TMAP1A	Bidirectional
3	TMAP1B	Bidirectional
4	Ground	-
5	GPS Position In	Input
6	Ground	-
7	TIS Traffic Out	Output
8	TMAP2A	Bidirectional
9	TMAP2B	Bidirectional
10	Ground	-
11	Controller Power	Output
12	Ground	-
13	Power ON	Input
14	Ground	-
15	11-33V DC	Input
16	Reserved	-

17	External Standby In	Input
18	Mutual Suppression	Bidirectional
19	Squat Switch In	Input
20	Ident Switch In	Input
21	Reserved	-
22	Reserved	-
23	Reserved	-
24	Reserved	-
25	Reserved	-

The following diagram shows the connector orientation as viewed from the wiring side.

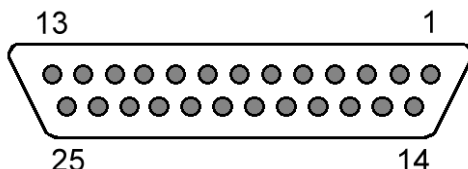

5.6 TT21/TT22 Transponder Interface Details

5.6.1 Power Input

The power supply can be 11-33 Volts DC; no voltage adjustment is required. Use a 3 Amp circuit breaker for power supply protection to the TT21/TT22.

It is always good practice to use more than one ground wire in an installation. This is particularly important when the transponder is mounted on a non-conducting surface, such as a composite structure. With only one wire there could be only a single grounding path for the transponder, controller and antenna.

Note: The transponder power input is not protected against reversed

power connections. Reversing the power and ground inputs to the transponder will destroy it. Check wiring before applying power.

5.6.2 TMAP Bus

TMAP is a Trig proprietary bus based on RS485 signalling. It provides a bi-directional interface between the transponder and the control head. Each TMAP interface comprises a balanced pair of signals, called A and B, both of which must be connected for communication to work.

There are two sets of TMAP pins on the TT21/TT22, TMAP1 A and B, and TMAP2 A and B. This is to support future installation wiring options. The two sets are identical, and either pair (TMAP1 or TMAP2) may be used to connect to the control head.

5.6.3 Power On

The TT21/TT22 power supply can be directly controlled by this discrete input. The input is active low, so that the TT21/TT22 will power up whenever the input is held low. This signal is intended to connect to the TC20 Remote ON output.

5.6.4 Controller Power

The TC20 controller does not connect to aircraft power – it receives power from the TT21/TT22 using this output. The TT21/TT22 provides 6.5 Volts to the TC20. This output includes short circuit protection, and no fuse is required between the TT21/TT22 and the TC20.

5.6.5 Mutual Suppression

Mutual suppression allows two or more transmitters on adjacent frequencies to inhibit the other transmitters when one is active to limit the interference effects. It is commonly used between transponders and DME systems, and between transponders and collision avoidance systems.

The Suppress I/O on pin 18 is an ARINC compatible suppression bus interface, which acts as both an input and an output. The TT21/TT22 will

assert this signal when it is transmitting, and can be suppressed by other equipment that asserts the signal. The TT21/TT22 will drive approximately 24 Volts on the output (independently of supply voltage), and will treat the input as active whenever the bus has greater than 10 Volts.

5.6.6 Ident Switch Input

The Ident switch input allows the IDENT function to be selected using a remote switch. The input is active low, and will be asserted when the voltage to ground is pulled below approximately 4 Volts.

5.6.7 Squat Switch Input

The Squat switch input allows the transponder to automatically switch between Airborne and Ground modes, and affects both the Mode S reply behaviour and the ADS-B reporting behaviour. The input will be asserted when the voltage to ground is pulled below approximately 4 Volts. The logical sense of the input can be programmed to be either active low or active high.

On an aircraft with no appropriate squat switch circuit this input should be left unconnected, and the transponder programmed to ignore the input.

5.6.8 External Standby Input

This input, when held low, places the transponder in Standby mode. It should be used to switch between transponders in an installation with two transponders. The input is active low, and will be asserted when the voltage to ground is pulled below approximately 4 Volts.

5.6.9 GPS Position Input

The GPS position input is required to support ADS-B functionality. The GPS position input is an RS232 input to the transponder. The ADS-B features are optional – no GPS is required for normal Mode S Elementary Surveillance.

The TT21/TT22 GPS input can recognise the following protocols:

- Industry standard “Aviation” protocol
- NMEA 0183 protocol
- Freeflight and NexNav GPS proprietary protocols
- Garmin ADS-B protocol

The interface speed can be selected between 4800, 9600 and 19200 bps.

Some of the protocols listed above may not contain all the required data for a compliant ADS-B message, depending on the intended airspace regulations. For further information refer to Section 12 (ADS-B Compliance) of this manual.

5.6.10 TIS Traffic Output

The TIS traffic is an RS232 output and supports the display of uplinked Traffic Information Service messages. The TT21/TT22 TIS output can drive the Trig proprietary traffic protocol, and can also support the format used by certain Garmin handheld displays, including the 495, 496, 695 and 696.

Note: TIS is a Mode S uplink service that is provided by some US approach radars. TIS coverage is limited to the coverage areas of those radars. There is no TIS provision outside the USA.

5.7 TC20 Controller Electrical Connections

The TC20 controller has a single 9 way D type male connector to link to the transponder, and optionally to connect to a GPS for baro-aiding.

5.7.1 TC20 Interface - Pinout

Pin	Signal	Direction
1	Ground	-
2	TMAPA	Bidirectional
3	TMAPB	Bidirectional

4	Altitude Out	Output
5	Reserved	Input
6	Ground	-
7	Remote ON	Output
8	Power	Input
9	Ground	-

The following diagram shows the connector orientation as viewed from the wiring side.

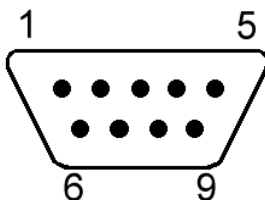

5.8 TC20 Controller Interface Details

5.8.1 TMAP Bus

TMAP is a Trig proprietary bus based on RS485 signalling. It provides a bi-directional interface between the transponder and the control head. Each TMAP interface comprises a balanced pair of signals, called A and B, both of which must be connected for communication to work.

TMAP A and B lines on the controller should be connected to the corresponding A and B lines of either TMAP1 or TMAP2 on the TT21/TT22.

5.8.2 Altitude Out

The TC20 incorporates an altitude encoder. Certain GPS receivers can benefit from having altitude information supplied to them. The TC20 reports pressure

altitude on this pin as an RS232 serial data format, at 9600 bps, using the format commonly called "Icarus" or "Garmin" format.

5.8.3 Remote ON

This output is connected directly to the Power/Mode switch on the TC20, and should be connected to the Power ON discrete input of the TT21/TT22.

5.8.4 Power

The TC20 uses 6.5 volts which is available from the TT21/TT22 transponder. This input should NOT be connected to aircraft power.

5.9 D Connector Crimp Terminals

The 25 way and 9 way connectors supplied with the TT21/TT22 installation kit are MIL standard versions of the popular sub miniature D type connector family, and use individual crimp terminals and a receptacle. The MIL specification for this family of connectors is MIL-C-24308. We supply crimp terminals because these are more reliable than soldered connections, and are easier to assemble in-situ in an aircraft, where soldering is impractical. They also allow individual wires to be removed and replaced in a receptacle without replacing the whole connector.

The pin contacts, used in the 25 way connector, conform to MIL part number M39029/64-369, and are suitable for wire gauges from 20 to 24 AWG.

The socket contacts, used in the 9 way connector, conform to MIL part number M39029/63-368, and are also suitable for wire gauges from 20 to 24 AWG.

These contacts are widely used in avionics installation, and there are many tools available on the market that will reliably crimp them to the wiring. Because the contacts are a MIL standard, there is also a MIL standard for the crimp tool, although other proprietary solutions are also available.

The MIL reference for the basic style of hand tool is M22520/2-01. This style of tool can crimp many different contact types, and relies on interchangeable "positioners" to hold the actual contact in use. The MIL reference for the

positioner that you need for the crimps we supply is M22520/2-08.

Any tool that complies with these references can be used to crimp these contacts. One of the most popular vendors of these small hand tools is Daniels Manufacturing Corporation (see www.dmctools.com). Their AFM8 hand tool complies with M22520/2-01, and their K13-1 positioner is M22520/2-08 compliant, so the combination will crimp the supplied connectors.

Once crimped, the contacts should be slotted into the rear of the connector shell. Push the contact in until the retaining tab clicks into place. Tug gently to confirm the contact is locked in place.

5.10 Wiring Considerations

The connection from the TT21/TT22 transponder to the TC20 uses a minimum of six (6) signal lines; the TMAP pair, the Power and Ground pair, and the Remote On discrete line plus associated ground line. In a certified installation the normal wire choice would be Tefzel hook-up wire. Wire of 20 AWG is more than adequate for the task; in installations where weight is an issue, wire of 22 or 24 AWG can also be used. Where lighter wires than 20 AWG are used the individual wires should be laced together for support.

The TT21/TT22/TC20 was tested and certified using unshielded, untwisted wiring, and that is sufficient for a certified installation. There may however be technical benefits of improved electromagnetic emissions and susceptibility to and from the transponder system if the two wires of the TMAP pair are lightly twisted together – one twist per 1 to 2 inches is appropriate. This may reduce interference and break-through on adjacent audio wiring if it is not possible to route them separately. For tidiness and consistency the other pairs in the bundle can also be twisted, but there will be no particular difference in behaviour.

The distance between the TT21/TT22 transponder and the TC20 controller is limited by the impedance of the wire between them. The TC20 is powered from the TT21/TT22, not from aircraft power, and therefore the acceptable voltage drop in the power line is what limits the distance. The TC20 needs an impedance of less than 0.5 ohm in the power line for satisfactory operation. The following table gives guidelines for typical aircraft hook-up wire. Note that different brands may vary – check your supplier for details.

Gauge	Ohm/km	Length for 0.5 Ohm
20 AWG	35	14.2 m
22 AWG	64	7.8 m
24 AWG	99	5.0 m

An alternative to a harness built from individual wires, particularly for a long cable run, is to use a multi-core cable. Aviation grade cable with 6 or more cores is often more expensive than the individual wires, and therefore is not generally a good choice for a certified aircraft. For aircraft where those considerations do not apply however, an attractive alternative solution may be to use 3 pair or 4 pair data cable.

Whilst appropriate cables may exist, please note that not all data cable is suitable for this application. Cables with solid cores should not be used, and cables should be selected based on the wear characteristics of their insulation material, including temperature rating, resistance to solvents and oils, and flammability. Most inexpensive commercial data cables have poor flammability properties.

5.11 Antenna Installation

The antenna should be installed according to the manufacturer's instructions.

The following considerations should be taken into account when siting the Antenna.

- The antenna should be well removed from any projections, the engine(s) and propeller(s). It should also be well removed from landing gear doors, access doors or others openings which will break the ground plane for the antenna.
- The antenna should be mounted on the bottom surface of the aircraft and in a vertical position when the aircraft is in level flight.
- Avoid mounting the antenna within 3 feet of the ADF sense antenna or any COMM antenna and 6 feet from the transponder to the DME antenna.

- Where practical, plan the antenna location to keep the cable lengths as short as possible and avoid sharp bends in the cable to minimise the VSWR.

Electrical connection to the antenna should be protected to avoid loss of efficiency as a result of the presence of liquids or moisture. All antenna feeders shall be installed in such a way that a minimum of RF energy is radiated inside the aircraft.

5.11.1 Antenna Ground Plane

When a conventional aircraft monopole antenna is used it relies on a ground plane for correct behaviour. For ideal performance the ground plane should be very large compared to the wavelength of the transmission, which is 275mm. In a metal skinned aircraft this is usually easy to accomplish, but is more difficult in a composite or fabric skinned aircraft. In these cases a metallic ground plane should be fabricated and fitted under the antenna.

As the ground plane is made smaller, the actual dimensions of the ground plane become more critical, and small multiples of the wavelength should be avoided, as should circles. Rectangles or squares are much less likely to create a critical dimension that resonates with the transmissions. The smallest practical ground plane is a square around 120mm per side; as the size increases the performance may actually get worse, but will be better by the time the ground plane is 700mm on each side. Anything much larger than that size is unlikely to show significant further improvement.

The thickness of the material used to construct the ground plane is not critical, providing it is sufficiently conductive. A variety of proprietary mesh and grid solutions are available. Heavyweight cooking foil meets the technical requirements, but obviously needs to be properly supported.

5.11.2 Antenna Cable

The TT21 is designed to meet Class 2 requirements with an allowance of 2 dB for loss in the connectors and cable used to connect it to the antenna. The TT22 is designed to meet Class 1 requirements with the same 2 dB allowance. Excessive loss will degrade both transmitter output power and receiver

sensitivity.

Allowing 0.25dB loss for the connector at each end of the antenna cable assembly leaves an allowance of 1.5dB maximum loss for the cable itself.

An acceptable cable:

- Has less than 1.5dB loss for the run length needed
- Has a characteristic impedance of 50 Ohms
- Has double braid screens or has a foil and braid screen

Once the cable run length is known, a cable type with low enough loss per metre that meets the above requirements can be chosen. Longer runs require lower loss cable. Consider moving the TT21/TT22 closer to the antenna to minimise the losses in the antenna cable – subject to the limits identified above, the TT21/TT22 can be at any distance from the control head without affecting performance in any way.

Note: Low loss cable typically uses foamed or cellular dielectrics and foil screens. These make such cables especially prone to damage from too-tight bends or from momentary kinking during installation. Once kinked, these cables do not return to full performance when straightened.

The following table is a guide to the maximum usable lengths of some common cable types. Actual cable loss varies between manufacturers, there are many variants, and the table is therefore based on typical data. Use it as a guide only and refer to the manufacturer’s data sheet for your specific chosen cable for accurate values.

Max Length in Metres	Max Length in Feet	Insertion Loss dB/metre at 1090MHz	MIL-C-17 Cables	Electronic Cable Specialists Type	SSB Electronic
2.54	8’ 4”	0.59	M17/128 (RG400)		
3.16	10’ 4”	0.47		3C142B	

Max Length in Metres	Max Length in Feet	Insertion Loss dB/metre at 1090MHz	MIL-C-17 Cables	Electronic Cable Specialists Type	SSB Electronic
3.81	12' 6"	0.39	M17/112 (RG304)		
4.50	14' 9"	0.33			Aircell 5
5.25	17' 3"	0.29	M17/127 (RG393)	311601	
6.42	21' 1"	0.23		311501	
6.81	22' 4"	0.22			Aircell 7
8.22	26' 11"	0.18		311201	
12.59	41' 3"	0.12		310801	

Contact Electronic Cable Specialists on +1 414 421 5300 or at www.ecsdirect.com for their data sheets. Contact SSB-Electronic GmbH on +49-2371-95900 or at www.ssb.de for their data sheets.

When routing the cable, ensure that you:

- Route the cable away from sources of heat.
- Route the cable away from potential interference sources such as ignition wiring, 400Hz generators, fluorescent lighting and electric motors.
- Allow a minimum separation of 300mm (12 inches) from an ADF antenna cable.
- Keep the cable run as short as possible.
- Avoid routing the cable round tight bends.
- Avoid kinking the cable even temporarily during installation.
- Secure the cable so that it cannot interfere with other systems.

5.11.3 TNC Connector

This section describes the technique for attaching the antenna cable to the supplied TNC connector.

If a low-loss cable is needed that has too large a dielectric diameter to fit the supplied connector, a short length (up to 150mm or 6 inches) of smaller cable may be used with suitable mating connectors to adapt to the transponder connector.

The supplied connector can be completed using a wide range of commercial crimp tools (for example the Tyco 5-1814800-3). The die apertures for the inner pin and the outer shield should be approximately 1.72 mm and 5.41 mm respectively.

- Strip back the coax cable to the dimensions in the table, as shown in the diagram below. Slide 25 mm (1 inch) of heat shrink tubing over the cable.
- Slide the outer crimp sleeve over the cable – it must go on before securing the centre contact.

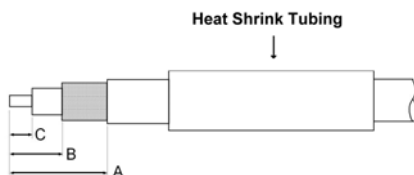

Dimension	Cut size (mm)	Cut size (inches)
A	17.5	0.69
B	7.2	0.28
C	4.8	0.19

- Crimp the centre contact to the cable.

- Insert the cable into the connector – the centre contact should click into place in the body, the inner shield should be inside the body of the connector and the outer shield should be outside the body.
- Crimp the outer sleeve over the shield.
- Slide heat shrink tubing forward (flush to connector) and heat to shrink the tubing.

5.12 Static Pressure Connection

The TC20 controller includes an altitude encoder which must be connected to the same source of static pressure as the primary altimeter on the aircraft. The TC20 static pressure port provides a mounting spigot intended for nominal 5mm or 3/16 inch inside diameter tubing. A length of 5mm EPDM rubber tubing is included in the installation kit to facilitate connection to the aircraft static system.

Choose a point in the existing static pressure line that is as close as practical to the TC20. Cut the static pressure line, and use the supplied T fitting to connect the altitude encoder. Take care not to contaminate the inside of the static line when cutting or inserting the connectors.

The following diagram shows the general arrangement, although other combinations may be used:

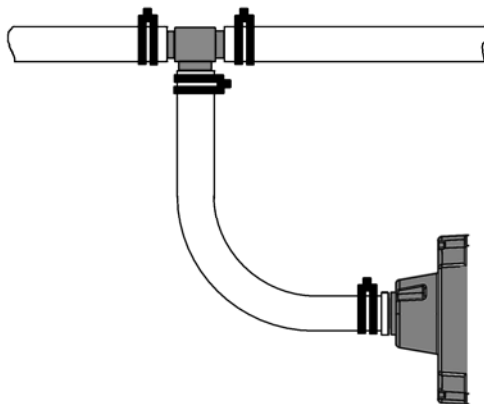

For aircraft with $\frac{1}{4}$ inch static lines, two adapters are provided which can convert from $\frac{1}{4}$ inch inside diameter hoses to the 5 mm hose in the install kit.

In all cases, the static line should include drainage provisions and should be routed in accordance with CS 23.1325 or other applicable airworthiness provisions for the aircraft.

6. Installation Setup and Test

The TT21/TT22 uses a simple setup system to program important system parameters, including the Mode S address. In the original factory configuration, the setup screen is the first thing that runs when you switch on the transponder. If the transponder has already been configured, and you want to access the setup screen again, hold down the FN button while switching on the transponder and the setup system will run.

The script will prompt for the following configuration items:

- Mode S Address
- VFR Squawk Code
- VFR Flight ID (Registration)
- Aircraft Maximum Airspeed
- Aircraft Category
- Squat switch source, if fitted
- TIS output format, if used
- GPS position source, if fitted, and ADS-B parameters

This setup mode also allows the recalibration of the altitude encoder.

All the programming is accomplished using the right hand rotary knob and the ENT and FN buttons. Make all input selections using the rotary knob. Pressing the ENT button accepts the current input and advances to the next input item. Pressing the FN button moves directly to the next screen.

6.1 Configuration Items

6.1.1 Aircraft Address Programming

The Mode S Address is a 24 bit number issued to the aircraft by the registration authority for the aircraft. These addresses are usually written as a

6 digit hexadecimal number, although you may also encounter one written as an 8 digit octal number. The TT21/TT22 only understands the hexadecimal format, so you must first convert an octal number to hexadecimal.

There is an Octal to Hexadecimal converter tool in the support section of the Trig Avionics web site.

Enter the 6 digit aircraft address using the rotary knob and the ENT button.

6.1.2 VFR Squawk Code

When the pilot presses the VFR button, a pre-programmed code will replace the current squawk code. The pre-programmed code is set up here; the choice of code will depend on the normal location of the aircraft. In the USA, the VFR squawk code is 1200. In most parts of Europe, the VFR squawk code should be set to 7000.

Enter the 4 digit squawk code using the rotary knob and the ENT button.

6.1.3 VFR Flight ID

The default Flight ID for an aircraft not on an IFR flight plan should be the aircraft registration. Enter the aircraft registration using the rotary knob and the ENT button.

Note that the aircraft registration is loaded as letters and numbers only. There are no dashes or other punctuation marks, and no spaces can be inserted. When you enter a space it finishes the data entry and moves to the next item.

6.1.4 Airspeed Category

Mode S transponders can transmit their maximum airspeed characteristics to aircraft equipped with TCAS. This information is used to help identify threats and to plan avoiding action by the TCAS equipped aircraft. The airspeeds are grouped in ranges; using the rotary knob, select the range that corresponds to the aircraft.

6.1.5 Aircraft Category

To assist ATC tracking of aircraft, an aircraft category can be transmitted by Mode S transponders. Using the rotary knob, select the aircraft category that most closely matches the aircraft the transponder is installed in.

6.1.6 Squat Switch Source

The Squat switch input allows the transponder to automatically switch between Airborne and Ground modes, and to automatically start and stop the flight timer. The sense of the squat switch input can be selected using the rotary knob. If the squat switch input is not connected the “Not Connected” option must be selected.

6.1.7 TIS Output

If the aircraft has a Traffic Information Service (TIS) compatible display connected to the transponder, select the appropriate interface protocol using the rotary knob.

Note: TIS is a Mode S uplink service that is provided by some US approach radars. TIS coverage is limited to the coverage areas of those radars; there is no TIS provision outside the USA.

6.1.8 GPS Input

If a GPS is connected for ADS-B position reporting, select the appropriate interface protocol using the rotary knob.

6.1.9 GPS/TIS Line Speed

If a GPS input or TIS output has been configured, you should select the appropriate line speed using the rotary knob. Traffic displays using the Garmin protocol run at 9600 bps. Panel mount GPS units with Aviation format outputs generally also run at 9600 bps. NMEA GPS units generally run at 4800 bps. Freeflight 1201 and NexNav 3101 GPS receivers generally run at 19200 bps.

Note: The TIS output and GPS input speeds are not separately controlled on the TT21/TT22. Not all combinations of GPS input and TIS output will be usable if the external devices operate on fixed bit rates and are different to each other.

6.1.10 GPS Certification Level

An important metric for ADS-B ground system behaviour is the SDA or System Design Assurance level. It is intended to reflect the probability that the GPS position source is providing erroneous information, and is based on the certification standard that was used by the GPS vendor. This will be indicated in the form of a letter code (A to D) on the data plate or installation documentation for the GPS in accordance with the standards DO-178B and DO-254, for example “DO-178B level C”. If both standards are reported but at different levels, use the lower standard (higher letter).

6.1.11 GPS NAC velocity

Another metric that the ADS-B ground system uses to help it track the aircraft is NACv. NACv is the Navigational Accuracy Category for velocity, and is a design feature of the GPS receiver. It represents the error bound for velocity that the GPS may report in acceleration/deceleration or turning manoeuvres. You can find this information from your GPS installation manual.

6.1.12 Aircraft Length and Width

On the ground, ADS-B transmits encoded aircraft size information which is used by ATC to identify taxiing routes and potential conflicts. When configured for ADS-B, the TT21/TT22 will ask for the aircraft length and width (wingspan), in metres, and will calculate the appropriate size code for transmission.

6.1.13 GPS Antenna Offset

The GPS antenna offset is used together with the aircraft length and width to manage taxiway conflicts. A typical GPS installation does not report the geographic position of the centre of the aircraft, or even the tip of the nose of

the aircraft; instead it usually reports the location of the actual GPS antenna (not the GPS receiver). In normal flight operations this distinction is of no practical importance at all, but if ADS-B is used to manage taxiway conflicts, a significant offset in antenna position could mean that the aircraft is not in the same place as the ADS-B reported position. Although primarily intended for position correction on large transport aircraft, General Aviation aircraft can also have a significant offset. For example, if the aircraft has a long tail boom and the GPS antenna is on the top of the tail, the GPS position could be 4 metres or more from the nose of the aircraft.

Enter the position of the GPs antenna relative to the nose of the aircraft. The position is stored and transmitted to the nearest 2 metres; great accuracy in measurement is not required.

6.1.14 1090 MHz Receiver Installed

The ADS-B transmissions include an indication to the ground stations of whether your aircraft includes a 1090 MHz ADS-B receiver. This can be used by the ground stations to manage the volume of traffic they must send. Set this to “Yes” if the aircraft has a 1090 MHz ADS-B receiver installed.

6.1.15 UAT Receiver Installed

The ADS-B transmissions include an indication to the ground stations of whether your aircraft includes a UAT ADS-B receiver. This can be used by the ground stations to manage the volume of traffic they must send. Set this to “Yes” if the aircraft has a UAT receiver installed.

6.2 Test and Calibration items

6.2.1 Voltage Check

The Voltage Check screen displays the current input voltage received by the control head from the TT21/TT22. Whilst displaying this screen the TC20 will exercise certain internal functions in the controller, including periodically turning on the heater circuit. The purpose of these exercises is to present a changing load on the power lines from the TT21/TT22. If you suspect a

potential problem with the wiring to the controller, it is worth monitoring the displayed voltage for several seconds to find the worst-case reading.

The nominal voltage is 6.5 Volts. The displayed value may be lower due to cable impedance. If the voltage is below 6.0 Volts, then the interface cable has too much impedance, and you should review the choice of cable.

6.2.2 Altitude Encoder Calibration

The Altitude Encoder Calibration allows you to adjust the built-in altitude encoder to ensure that the altitude transmitted by the transponder corresponds to the altitude seen by the pilot on the primary altimeter. This process is normally carried out every 24 months, as part of the altimeter checks on the aircraft. The maximum allowed difference between the primary altimeter and the altitude encoder is 125 feet in ETSO C88a and TSO C88b. The altitude encoder in the TC20 is accurately calibrated during manufacture to be within 50 feet of the applied pressure altitude at all altitudes, whereas the allowed error in the primary altimeter increases with altitude, and above 18,000 feet the altimeter error alone may exceed 125 feet. It is therefore possible that the combination of the allowed errors in the encoder and the primary altimeter may exceed 125 feet, in which case the altitude encoder must be adjusted to correspond to the primary altimeter.

Note: The purpose of calibrating the encoder is to make the output correspond to the primary altimeter. The encoder calibration procedure must therefore only be undertaken after the primary altimeter has been tested and found to comply with the relevant standards.

6.2.2.1 Calibration Equipment

To calibrate the encoder you will need to be able to power up the transponder subsystem, and you will need a pitot-static test set with the appropriate adapters to connect to the static port on the aircraft. The pitot-static test set should be able to drive the altitude down to sea level, and above the service ceiling of the aircraft.

No transponder test set is required – the calibration procedure displays all the

information you need on the screen of the TC20

6.2.2.2 Calibration Procedure

There are four adjustment points on the altitude encoder, a low altitude adjustment point, two mid-level adjustments, and a high altitude adjustment point. The low altitude point adjusts the correspondence at sea level, the first mid level point adjusts the correspondence around FL100, the second mid level point adjusts the correspondence at around FL200, and the high altitude point adjusts the correspondence at FL300 and above. Since the altitude limit of the encoder is likely to be higher than the service ceiling of the aircraft, it is sufficient to set only those adjustment points at or below the service ceiling of the aircraft.

Note: DO NOT EXCEED THE ALTITUDE OR RATE OF CLIMB LIMITS OF THE PITOT-STATIC INSTRUMENTS OF THE AIRCRAFT. The Trig altitude encoder is a solid state device and will not be affected by excess altitude or rate of climb and descent, but the mechanical instruments in the aircraft can easily be damaged by being driven beyond their intended range.

Proceed as follows:

1. Set the primary altimeter subscale setting to 1013.2 hPa, 29.92 in hg.
2. Connect the pitot-static test set to the aircraft.
3. Power up the transponder and controller, whilst holding the FN button down on the controller. This will enter SETUP mode on the controller.
4. Skip over the configuration modes until reaching the encoder calibration section.
5. Accept the Yes/No question; the LOW ALTITUDE set point will now be active, and an altitude will be displayed.
6. On the static test set, drive the altitude to 0 feet.
7. Read the primary altimeter value, and turn the right knob on

- the TC20 until the altitude displayed on the TC20 matches the altitude on the primary altimeter.
8. Press ENT on the TC20; the display will move to the MID ALTITUDE FL100 set point.
 9. On the static test set, drive the altitude to 10,000 feet.
 10. Read the primary altimeter value, and turn the right knob on the TC20 until the altitude displayed on the TC20 matches the altitude on the primary altimeter.
 11. Press ENT on the TC20; the display moves to the MID ALTITUDE FL200 screen.
 12. If the service ceiling of the aircraft is below 20,000 feet, the process is complete. Press the ENT button twice more to get to the test screen. Otherwise, proceed to step 13.
 13. On the static test set, drive the altitude to 20,000 feet.
 14. Read the primary altimeter value, and turn the right knob on the TC20 until the altitude displayed on the TC20 matches the altitude on the primary altimeter.
 15. Press ENT on the TC20; the display moves to the HIGH ALTITUDE FL300 screen.
 16. If the service ceiling of the aircraft is below 30,000 feet, the process is complete. Press the ENT button once more to get to the test screen. Otherwise, proceed to step 17.
 17. On the static test set, drive the altitude to 30,000 feet.
 18. Read the primary altimeter value, and turn the right knob on the TC20 until the altitude displayed on the TC20 matches the altitude on the primary altimeter.
 19. Press ENT on the TC20; the display moves to the test screen.

To complete the testing you should leave the TC20 screen displaying the encoder altitude, and exercise the altitude on the static test set across the

altitude range of the aircraft. Use at least 10 test points, and verify that in each case the altitude displayed on the primary altimeter and the altitude displayed on the TC20 correspond within the 125 foot tolerance. Lightly tap the altimeter at each test point to eliminate friction effects.

When the correspondence test is complete, press ENT again on the TC20, and power off the system.

7. Post Installation Checks

Post installation checks should be carried out in accordance with your certification requirements. These checks should include:

- Mode S interrogations to verify correct address programming.
- Verification of the reported altitude using a static tester.
- Where installed, verification of correct squat switch ground/airborne indications. In an aircraft with a squat switch, setting the Mode switch to ALT when the aircraft is on the ground should leave the transponder in GND mode; when the aircraft becomes airborne, the mode should switch automatically to ALT.
- Interrogations to verify the receiver sensitivity. A Mode S transponder should have a minimum triggering level (MTL) of between -77 dBm and -71 dBm. Failure to meet this requirement usually indicates antenna or coaxial cable problems.
- Interrogations to verify the transmitted power. A Class 1 installation should have no less than 125 Watts at the antenna (and no more than 500 Watts). A Class 2 installation should have no less than 71 Watts at the antenna (and no more than 500 Watts). Failure to meet this requirement is also generally due to antenna or wiring issues.
- Where installed, verification of the GPS position source and ADS-B outputs. Whenever a valid position is received by the transponder and the transponder is in any mode other than Standby, ADS-B Extended Squitters should be observed on the transponder test set.

8. Normal Operation

8.1 Overview

On the front panel is a monochrome LCD display flanked by a rotary mode selector knob (OFF, SBY, GND, ON, and ALT) and a continuously rotating knob used for code and data entry.

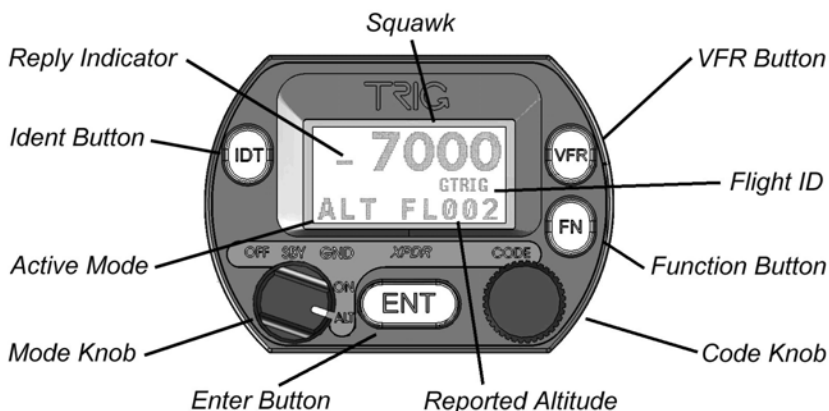

8.2 Display

The display shows the operating mode of the transponder, the reported pressure altitude, and the current squawk code and Flight ID. The reply indicator is active when the transponder replies to interrogations.

The pressure altitude is displayed as a Flight Level, which is the pressure altitude in hundreds of feet. When non-standard atmospheric conditions apply, this may not match the altimeter indicated altitude, but will be correctly displayed by the ATC radar.

8.3 Mode Selector Knob

The left hand knob controls the power to the transponder and the operating mode.

- OFF Power is removed from the transponder.
- SBY The transponder is on, but will not reply to any interrogations.
- GND The transponder will respond to Mode S ground interrogations from surface movement radar.
- ON The transponder will respond to all interrogations, but altitude reporting is suppressed.
- ALT The transponder will respond to all interrogations.

When airborne, the transponder should always be set to ALT unless otherwise directed by Air Traffic Control. When you are taxiing on the ground, the transponder should be set to GND unless your installation includes a gear squat switch which will automatically select GND on landing.

8.4 Push Buttons

- IDT Press the IDT button when ATC instructs you to “Ident” or “Squawk Ident”. This activates the SPI pulse in the transponder replies for 18 seconds. IDT will appear in the display.
- FN Pressing the FN button provides access to changing the Flight ID and the ADS-B position monitor.
- VFR Pressing the VFR button sets the transponder to the pre-programmed conspicuity code. Pressing the button again restores the previous squawk code.
- ENT The ENT button enters a digit in the code selector.

8.5 Code Selector Knob

The right hand knob is used to set squawk codes and the Flight ID. The FN button selects which will be updated. Turning the knob will highlight the first

digit on the display, and the digit can be changed as required. Press the ENT button to advance to the next digit. When ENT is pressed on the last digit, the new squawk code or Flight ID will replace the previous value. If the code entry is not completed within 7 seconds, the changes are ignored and the previous code restored.

1200	VFR code in the USA
7000	VFR code commonly used in Europe.
7500	Hijack code
7600	Loss of communications
7700	Emergency code

The Flight ID should correspond to the aircraft call sign entered on your flight plan. If no flight plan is active, the aircraft registration should be used as your Flight ID. Use only letters and digits. If the Flight ID is less than 8 characters long, entering a blank character will end it.

8.6 Altitude Encoder Warm Up

The built in altitude encoder uses a sensor that is temperature dependent. A small internal heater circuit keeps the sensor at the correct temperature. When the ambient temperature is below 0°C there may be a delay between switching on the transponder and seeing an altitude reported. In very cold weather this delay can be up to 5 minutes. You should always switch on the transponder (usually to GND mode) before taxiing to the runway, to ensure that the sensor is operating before you become airborne.

8.7 General Low Temperature Operation

The TT21/TT22 is certified to operate correctly down to -20°C, but at low temperatures the display may be impaired. On a cold day you may need to wait for the cockpit to warm up to ensure normal operation.

8.8 ADS-B Monitor

The ADS-B Monitor is only available on installations that include an ADS-B position source. The ADS-B Monitor provides a display of the position information that is being transmitted in ADS-B position reports. This can provide confirmation that the correct information is being transmitted, particularly where the GPS source is remote from the transponder.

In the event that valid position information is NOT available from the GPS, the latitude and longitude display will be replaced by dashes; if no valid latitude and longitude is shown then ADS-B position information is NOT being transmitted.

8.9 Warning Messages

If the transponder detects a problem, the screen will indicate WARNING and a brief statement of the problem. Depending on the nature of the problem, your transponder may not be replying to interrogations. Note the message on the screen and pass that information to your avionics maintenance organisation. Press ENT to clear the message; if the fault is still present the message will reappear.

8.10 Fault Annunciation

If the transponder detects a catastrophic internal failure, the screen will indicate FAULT and a brief statement of the problem. No replies will be made to interrogations when a fault has been detected.

Some FAULT indications can be recovered by switching the transponder off and back on again, although in all cases a FAULT code implies that there is a fault with the transponder or the installation. Note the FAULT message shown on the screen and pass that information to your avionics maintenance organisation.

9. Continued Airworthiness

Other than for periodic functional checks required by the regulations, the TT21/TT22 Mode S transponder has been designed and manufactured to allow “on condition maintenance”. This means that there are no periodic service requirements necessary to maintain continued airworthiness, and no maintenance is required until the equipment does not properly perform its intended function. When service is required, a complete performance test should be accomplished following any repair action. Repairs should only be carried out in accordance with Trig Avionics Limited service procedures.

10. Limited Warranty

Trig Avionics Limited warrants our products to be free from defects in materials and workmanship for a period of two (2) years from the date of installation by an authorised dealer.

This warranty covers repair and/or replacement at our option, of any parts found to be defective, provided such defects in our opinion are due to faulty material or workmanship and are not caused by tampering, abuse, or normal wear.

All warranties are F.O.B.

Trig Avionics Limited
Heriot Watt Research Park
Riccarton, Currie, EH14 4AP

Trig Avionics will not accept or pay for any charges for warranty work performed outside our factory without prior written consent.

This warranty applies only to products in normal use. It does not apply to units or circuit boards defective due to improper installation, physical damage, tampering, lightning or other electrical discharge, units with altered serial numbers, or units repaired by unauthorised persons or in violation of Trig Avionics Limited service procedures.

Trig Avionics Limited assumes no responsibility for any consequential losses of any nature with respect to any products or services sold, rendered, or delivered.

11. Environmental Qualification Forms

Nomenclature:	TT21 Mode S Transponder	
Part No: 00675-00-01	ETSO: 2C112b, C166a	
Manufacturer:	Trig Avionics Limited	
Address:	Heriot Watt Research Park, Riccarton, Currie, Scotland, EH14 4AP	
Conditions	DO-160F Section	Description of Conducted Tests
Temperature and Altitude	4.0	Equipment tested to Categories A2, C1
Low temperature ground survival	4.5.1	-55°C
Low temperature short-time operating	4.5.1	-40°C
Low temperature operating	4.5.2	-20°C
High temperature operating	4.5.4	+70°C
High temperature short-time operating	4.5.3	+70°C
High temperature ground survival	4.5.3	+85°C
Loss of Cooling	4.5.5	Cooling air not required (+70°C operating without cooling air)
Altitude	4.6.1	35,000 feet
Decompression	4.6.2	8,000 to 35,000 feet in 15 seconds
Overpressure	4.6.3	-15,000 feet
Temperature Variation	5.0	Equipment tested to Category C
Humidity	6.0	Equipment tested to Category A
Operational Shocks	7.2	Equipment tested to Category B
Crash Safety	7.3	Equipment tested to Category B type 5

Vibration	8.0	Aircraft zone 2; type 3, 4, 5 to category S level M, type 1 (Helicopters) to category U level G
Explosion	9.0	Equipment identified as Category X – no test required
Waterproofness	10.0	Equipment identified as Category X – no test required
Fluids Susceptibility	11.0	Equipment identified as Category X – no test required
Sand and Dust	12.0	Equipment identified as Category X – no test required
Fungus	13.0	Equipment identified as Category X – no test required
Salt Spray	14.0	Equipment identified as Category X – no test required
Magnetic Effect	15.0	Equipment tested to Category Z
Power Input	16.0	Equipment tested to Category BX
Voltage Spike	17.0	Equipment tested to Category B
Audio frequency conducted susceptibility	18.0	Equipment tested to Category B
Induced signal susceptibility	19.0	Equipment tested to Category AC
Radio frequency susceptibility	20.0	Equipment tested to Category TT
Radio frequency emission	21.0	Equipment tested to Category B
Lightning induced transient susceptibility	22.0	Equipment identified as Category XXXX – no test required
Lightning direct effects	23.0	Equipment identified as Category X – no test required
Icing	24.0	Equipment identified as Category X – no test required
Electrostatic Discharge	25.0	Equipment identified as Category X – no test required
Fire, Flammability	26.0	Equipment identified as Category C

Nomenclature:	TT22 Mode S Transponder	
Part No: 00745-00-01	ETSO: 2C112b, C166a	
Manufacturer:	Trig Avionics Limited	
Address:	Heriot Watt Research Park, Riccarton, Currie, Scotland, EH14 4AP	
Conditions	DO-160F Section	Description of Conducted Tests
Temperature and Altitude	4.0	Equipment tested to Categories A2, C1
Low temperature ground survival	4.5.1	-55°C
Low temperature short-time operating	4.5.1	-40°C
Low temperature operating	4.5.2	-20°C
High temperature operating	4.5.4	+70°C
High temperature short-time operating	4.5.3	+70°C
High temperature ground survival	4.5.3	+85°C
Loss of Cooling	4.5.5	Cooling air not required (+70°C operating without cooling air)
Altitude	4.6.1	35,000 feet
Decompression	4.6.2	8,000 to 35,000 feet in 15 seconds
Overpressure	4.6.3	-15,000 feet
Temperature Variation	5.0	Equipment tested to Category C
Humidity	6.0	Equipment tested to Category A
Operational Shocks	7.2	Equipment tested to Category B
Crash Safety	7.3	Equipment tested to Category B type 5
Vibration	8.0	Aircraft zone 2; type 3, 4, 5 to category S level M, type 1 (Helicopters) to category U level G
Explosion	9.0	Equipment identified as Category X – no test required

Waterproofness	10.0	Equipment identified as Category X – no test required
Fluids Susceptibility	11.0	Equipment identified as Category X – no test required
Sand and Dust	12.0	Equipment identified as Category X – no test required
Fungus	13.0	Equipment identified as Category X – no test required
Salt Spray	14.0	Equipment identified as Category X – no test required
Magnetic Effect	15.0	Equipment tested to Category Z
Power Input	16.0	Equipment tested to Category BX
Voltage Spike	17.0	Equipment tested to Category B
Audio frequency conducted susceptibility	18.0	Equipment tested to Category B
Induced signal susceptibility	19.0	Equipment tested to Category AC
Radio frequency susceptibility	20.0	Equipment tested to Category TT
Radio frequency emission	21.0	Equipment tested to Category B
Lightning induced transient susceptibility	22.0	Equipment identified as Category XXXX – no test required
Lightning direct effects	23.0	Equipment identified as Category X – no test required
Icing	24.0	Equipment identified as Category X – no test required
Electrostatic Discharge	25.0	Equipment identified as Category X – no test required
Fire, Flammability	26.0	Equipment identified as Category C

Nomenclature	TC20 Mode S Controller	
Part Number: 00649-00	ETSO: 2C112b, C88a	
Manufacturer	Trig Avionics Limited	
Address	Heriot Watt Research Park, Riccarton, Currie, Scotland, EH14 4AP	
Conditions	DO-160F Section	Description of Conducted Tests
Temperature and Altitude	4.0	Equipment tested to Categories A4, C4
Low temperature ground survival	4.5.1	-55°C
Low temperature short-time operating	4.5.1	-25°C
Low temperature operating	4.5.2	-20°C
High temperature operating	4.5.3	+55°C
High temperature short-time operating	4.5.3	+70°C
High temperature ground survival	4.5.3	+85°C
Loss of Cooling	4.5.5	Cooling air not required (+70°C operating without cooling air)
Altitude	4.6.1	35,000 feet
Decompression	4.6.2	8,000 to 35,000 feet in 15 seconds
Overpressure	4.6.3	-15,000 feet
Temperature Variation	5.0	Equipment tested to Category A
Humidity	6.0	Equipment tested to Category A
Operational Shocks	7.2	Equipment tested to Category B
Crash Safety	7.3	Equipment tested to Category B type 5
Vibration	8.0	Aircraft zone 2; type 3, 4, 5 to category S level M, type 1 (Helicopters) to category U level G

Explosion	9.0	Equipment identified as Category X – no test required
Waterproofness	10.0	Equipment tested to Category W (front face only)
Fluids Susceptibility	11.0	Equipment identified as Category X – no test required
Sand and Dust	12.0	Equipment identified as Category X – no test required
Fungus	13.0	Equipment identified as Category X – no test required
Salt Spray	14.0	Equipment identified as Category X – no test required
Magnetic Effect	15.0	Equipment tested to Category Z
Power Input	16.0	Equipment identified as Category X – no test required
Voltage Spike	17.0	Equipment identified as Category X – no test required
Audio frequency conducted susceptibility	18.0	Equipment identified as Category X – no test required
Induced signal susceptibility	19.0	Equipment tested to Category BC
Radio frequency susceptibility	20.0	Equipment tested to Category TT
Radio frequency emission	21.0	Equipment tested to Category M
Lightning induced transient susceptibility	22.0	Equipment identified as Category XXXX – no test required
Lightning direct effects	23.0	Equipment identified as Category X – no test required
Icing	24.0	Equipment identified as Category X – no test required
Electrostatic Discharge	25.0	Equipment identified as Category X – no test required
Fire, Flammability	26.0	Equipment identified as Category C

12. ADS-B Compliance

TT21/TT22 transponders include support for Extended Squitter ADS-B out. The TT21/TT22 with software version 2.1 or higher is a DO-260B compliant broadcast participant.

12.1 ADS-B Parameters Supported

The following table summarises the ADS-B parameters that are transmitted by the TT21/TT22 transponder when connected to an appropriate GPS receiver.

Parameter		BDS Register
SPI		0,5
Emergency Indicator		0,5
Barometric Altitude		0,5
Quality Indicator (NIC)		0,5
Airborne Position	Latitude	0,5
	Longitude	0,5
Quality Indicator (NIC)		0,6
Surface Position	Latitude	0,6
	Longitude	0,6
Surface Ground Speed		0,6
Surface Ground Track		0,6
Aircraft Identification		0,8
Airborne Ground Velocity		0,9
Geometric to Barometric altitude difference		0,9
Geometric Vertical Rate		0,9

Squawk Code	6,1
Emergency Status	6,1
Quality Indicator (NAC _P)	6,5
Quality Indicator (NAC _V)	6,5
Quality Indicator (SIL)	6,5
Version Indicator	6,5
Surface Length/Width	6,5
Surface Antenna Offset	6,5

In all cases, uncompensated latency due to the transponder is less than 10 milliseconds. Analysis of the system latency should add this to the latency of the GPS system and the transmission time of the position data from the GPS to the transponder to determine the overall latency.

12.2 FAA 91.227 Compliance

The TT22 transponder can be connected to the following GPS units to form the basis of a 14 CFR 91.227 compliant ADS-B installation:

- Freeflight 1201 & 1204 WAAS/GPS Sensors
- NexNav MINI & NexNav MAX WAAS/GPS Sensors
- ~~Garmin GNS 400W/500W series~~

For installations seeking certification to 91.227 or other applicable standards, additional compliance information is available on request from Trig Avionics Limited.

12.3 AMC 20-24 Compliance

The TT21 or TT22 transponder can be connected to the following GPS units to form the basis of an AMC20-24 compliant ADS-B installation:

- Freeflight 1201 & 1204 WAAS/GPS Sensors

- NexNav MINI & NexNav MAX WAAS/GPS Sensors
- Garmin GNS 400W/500W series

For installations seeking certification to AMC 20-24 or other applicable standards, additional compliance information is available on request from Trig Avionics Limited.

12.4 Automatic Air/Ground Determination

The TT21/22 can report ADS-B surface and airborne messages. The squat switch input is designed to be used with an automatic air/ground switching device as defined in section 5.6.7.

12.5 ADS-B Support

If you require additional information and data to support an ADS-B installation then please contact support@trig-avionics.com.

13. Installation Drawings

13.1 Mounting tray fixing and overall dimensions

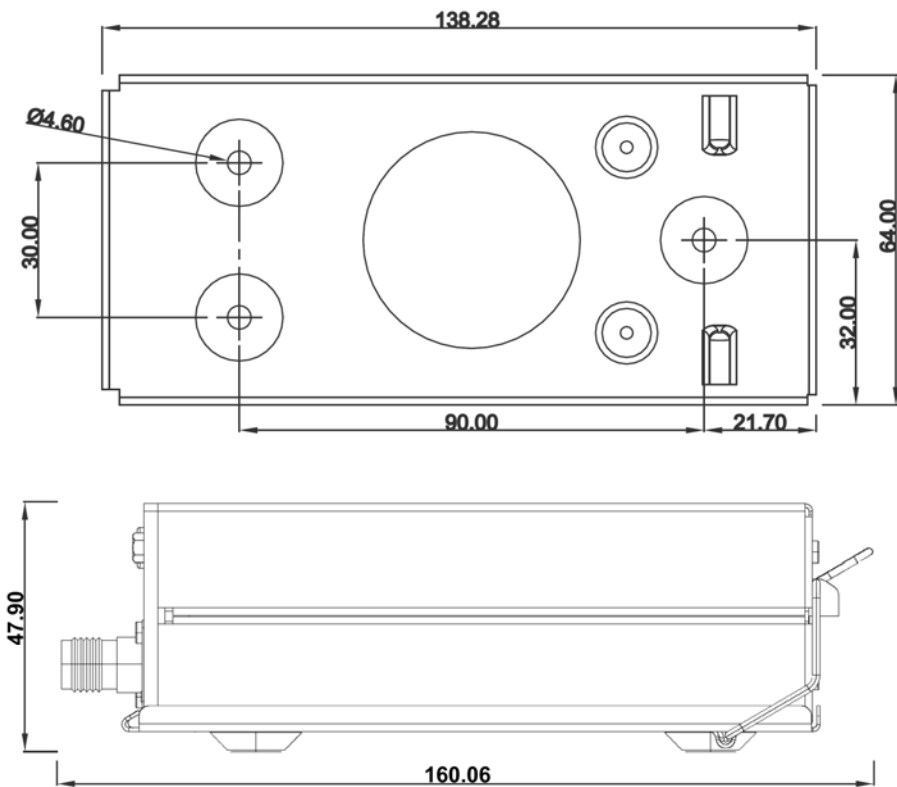

All dimensions in millimetres

13.2 Front Panel Controller Dimensions

Controller shown without the mounting adapters (00678-00) used for 57mm (2¼ inch) instrument mounting.

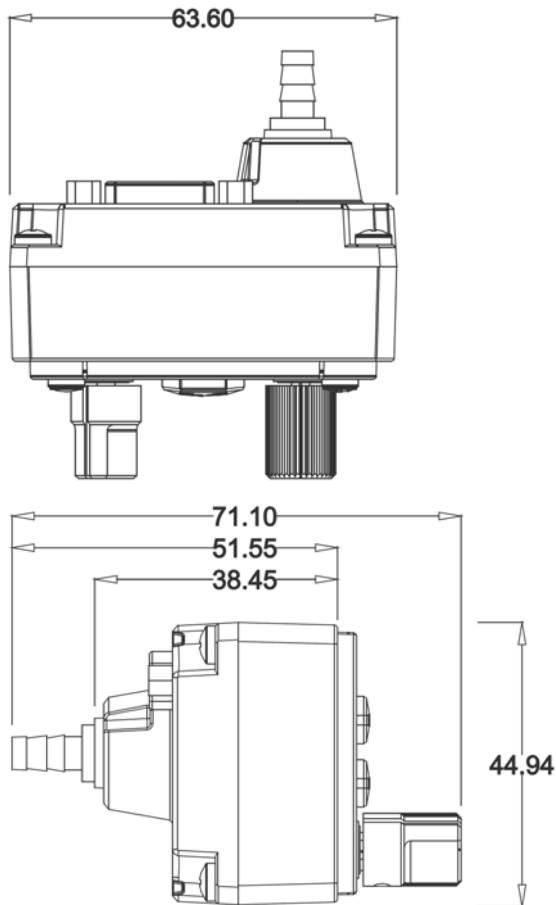

All dimensions in millimetres.

13.3 Front Panel Cut-out Options

The front panel controller can be fitted to either the compact mounting hole or a conventional 57mm (2¼ inch) instrument cut-out. The compact mounting is a truncated 58 mm opening; please note that the mounting screws are NOT in the same location for the two options.

Note: The following diagram is intended to be to scale, however variations in the printing process mean that you MUST check all dimensions before using it as a template.

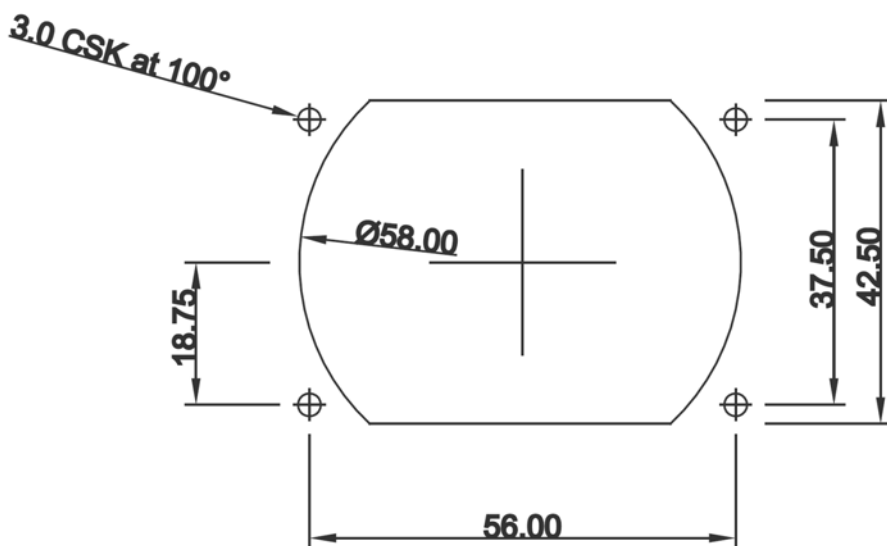

Note: The following diagram is intended to be to scale, however variations in the printing process mean that you MUST check all dimensions before using it as a template.

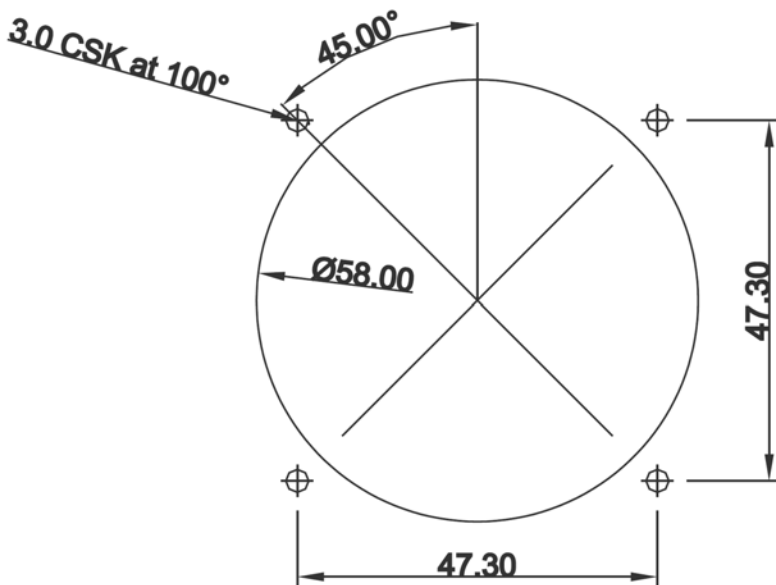

All dimensions in millimetres.

14. Basic Interconnect Diagram

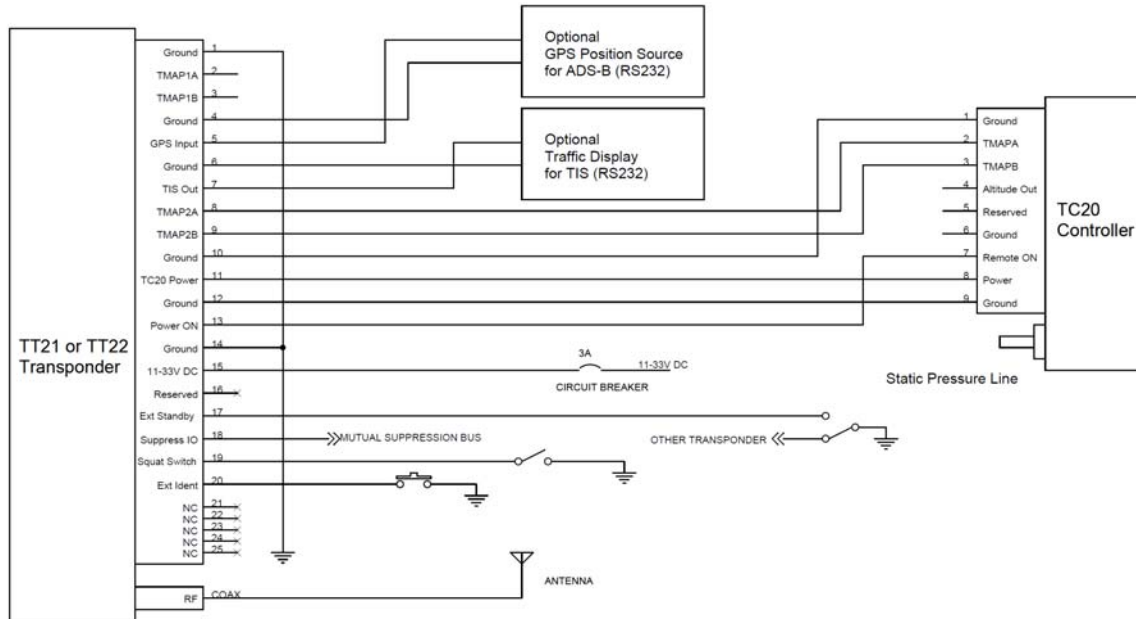

This page intentionally left blank